

030

01.05, 01.06, 01.09, 01.12, 01.20,
 01.21, 01.25, () 01.06; 01.16;
 01.20; 01.21; 01.22 () 102.
 12 18 10 ,
 20 13.

: +330° ; : +400° ; : +450° . N
 (. 1 . 1).

45°.

1,0 (10 / ²).

ASME 16.5-2003; DIN EN1092-1.

12821-80,

.2.

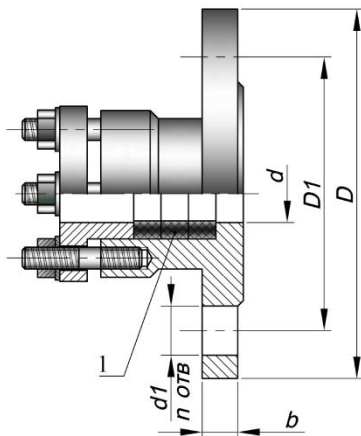

1
 030-01.DN. N-d

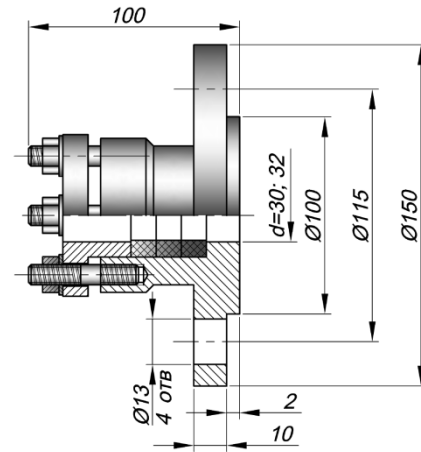

2
 030-00.50.25-30 (32)

030

() N: 1; 2,5; 6; 10; 16; 25; 40; 63 / ².
 DN: 20; 25; 32; 40; 50; 65; 80

	d	D	D1	d1	n	b		
030-00.50.25-30	30	150	115	13	4	10	40 30 5	2
030-00.50.25-32	32	150	115	13	4	10	42 32 5	
030- .DN.PN-10	10	90 (min)	DN 20 N 6,3				20 10 5	1
030- .DN.PN-20	20	120 (min)					30 20 5	
030- .DN.PN-27	27	130 (min)					37 27 5	
030- .DN.PN-30	30	130 (min)					40 30 5	
030- .DN.PN-32	32	130 (min)					42 32 5	

030 Ë .DN. N-d,

DN . (. .5 . 9-7);
 N . () / ²
 d .

030-02.32.16-20 .

030.

: 20 . () 2 Pn16, Dn32 12815.
 10 / ²