

038

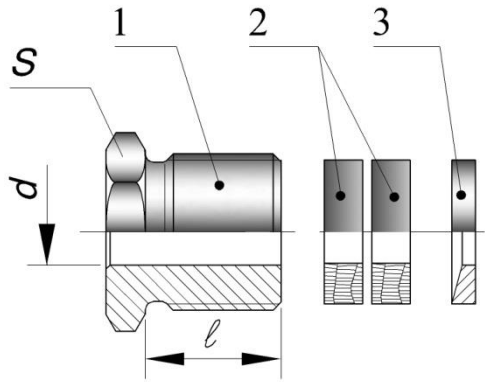

: +500° .
 () 1 .
 () .
 , , ,
 45°

034.4-20- -D-L
 01.01, 01.02, 02.01, 01.05, 01.09,
 () 01.06
 () 102, 106 108.
 : 1— ; 1 .
 2— , 2 ; 3—
 , 1 .
 20 13,
 — 12 18 10 .

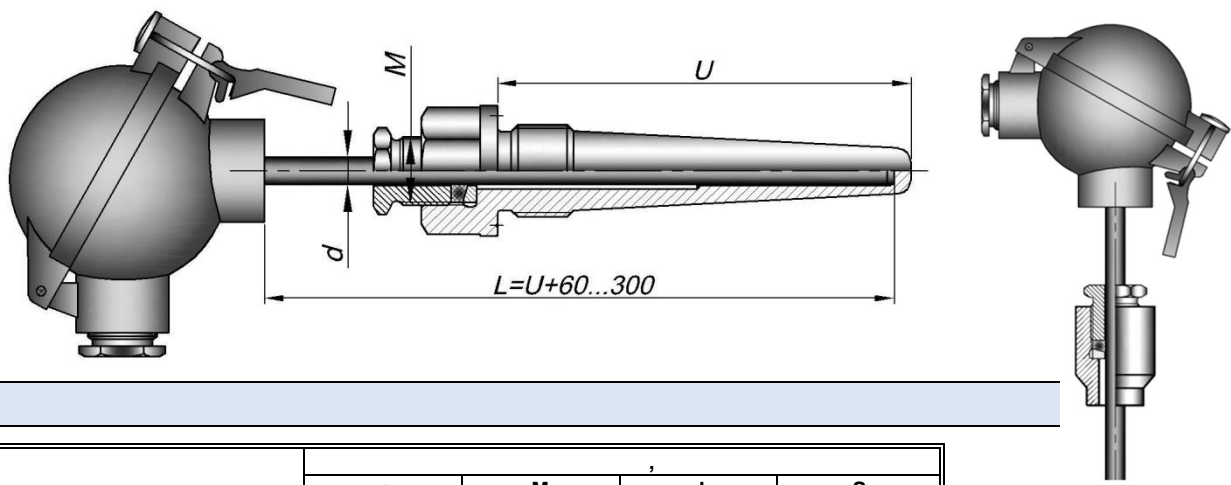

	<i>l</i>	M	d	S
038.20-10	16	20 1.5	10	22
038.20-8	16	20 1.5	8	22
038.20-6	16	20 1.5	6	22
038.20-4,5	16	20 1.5	4,5	22
038.33-20	18	33 2	20	32

038. Ęd —
 ; d.
 038.20Ę10 ĩ
 20 1,5.